

Locomotive rolling display -acrylic top assembly-

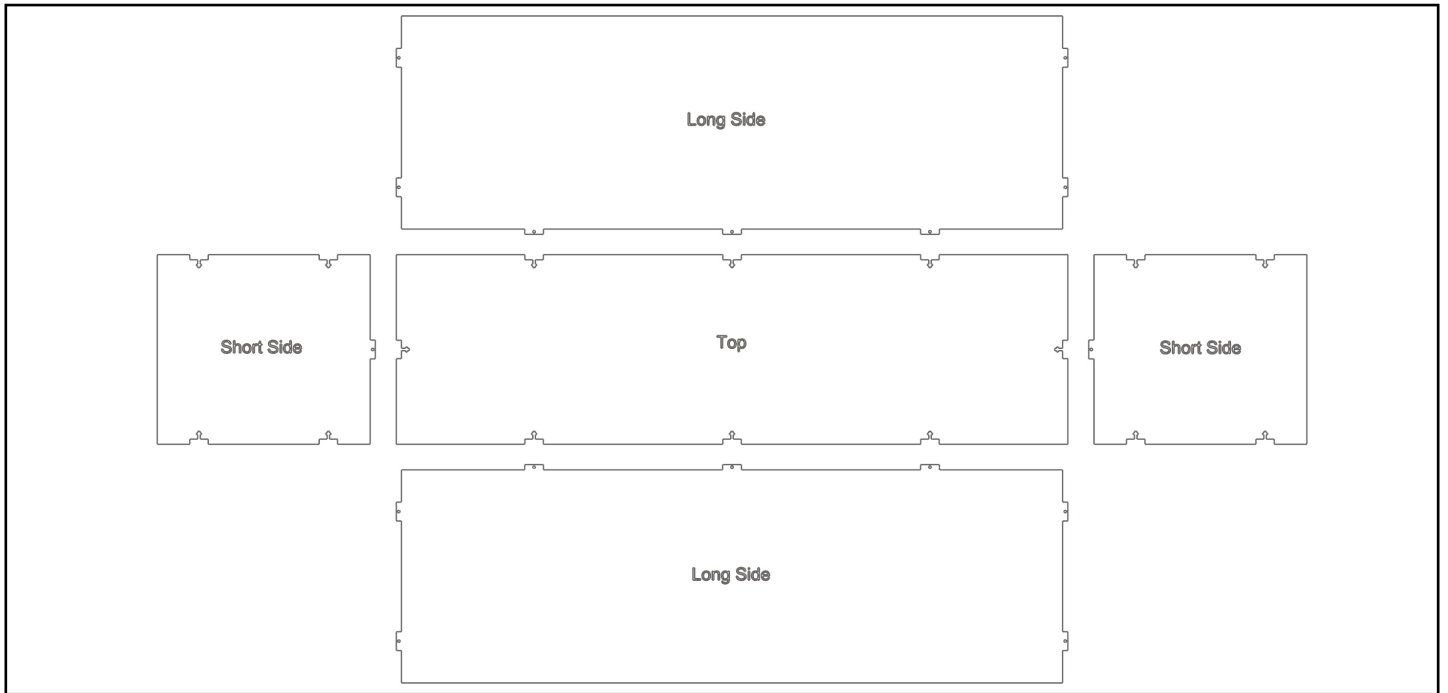

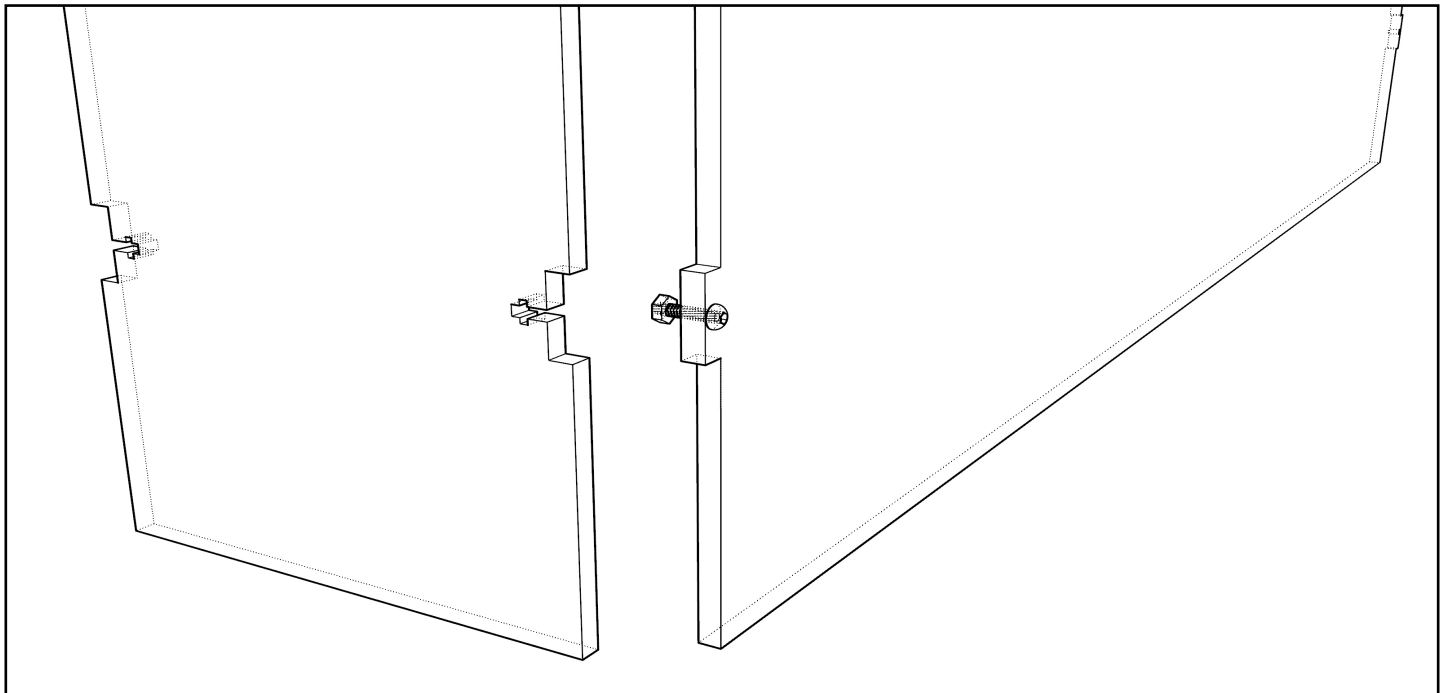

Remove the protection foil from both sides of the acrylic pieces. (green and clear)



Insert 1 screw to one of the long side panel hole adjacent to the short side.
Put the nut on the end of the screw, and place the short side panel next to it, slide the nut part into the joint.

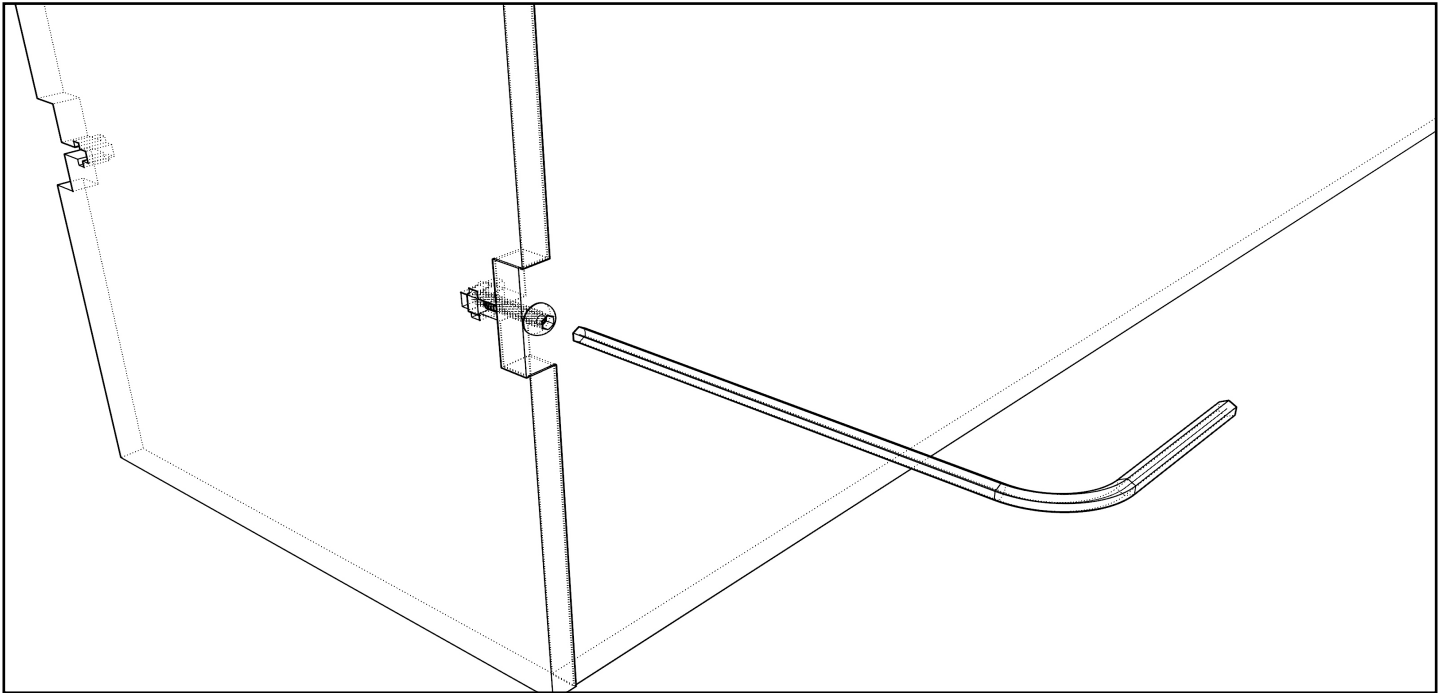

Tighten the screw gently with the 1.5mm hex key, do the same with the second screw on the same side,

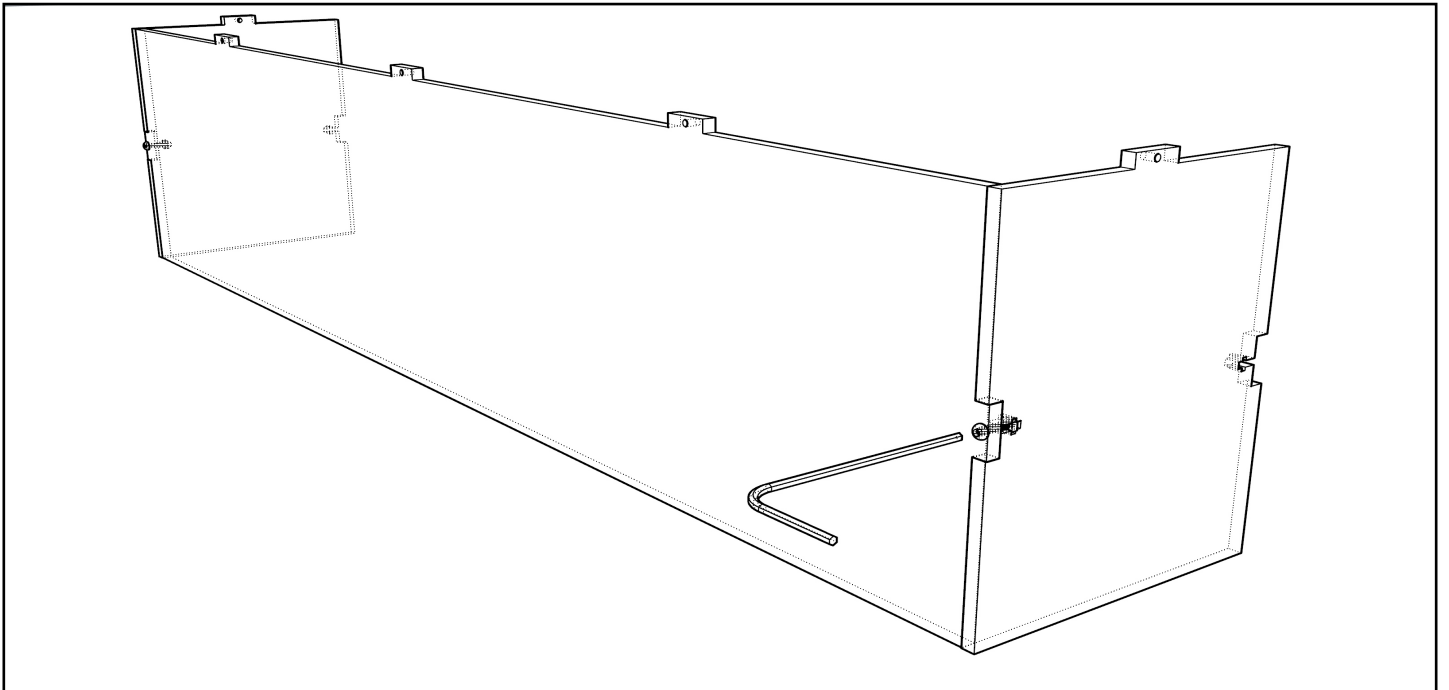

Mount the second short side panel the same way.

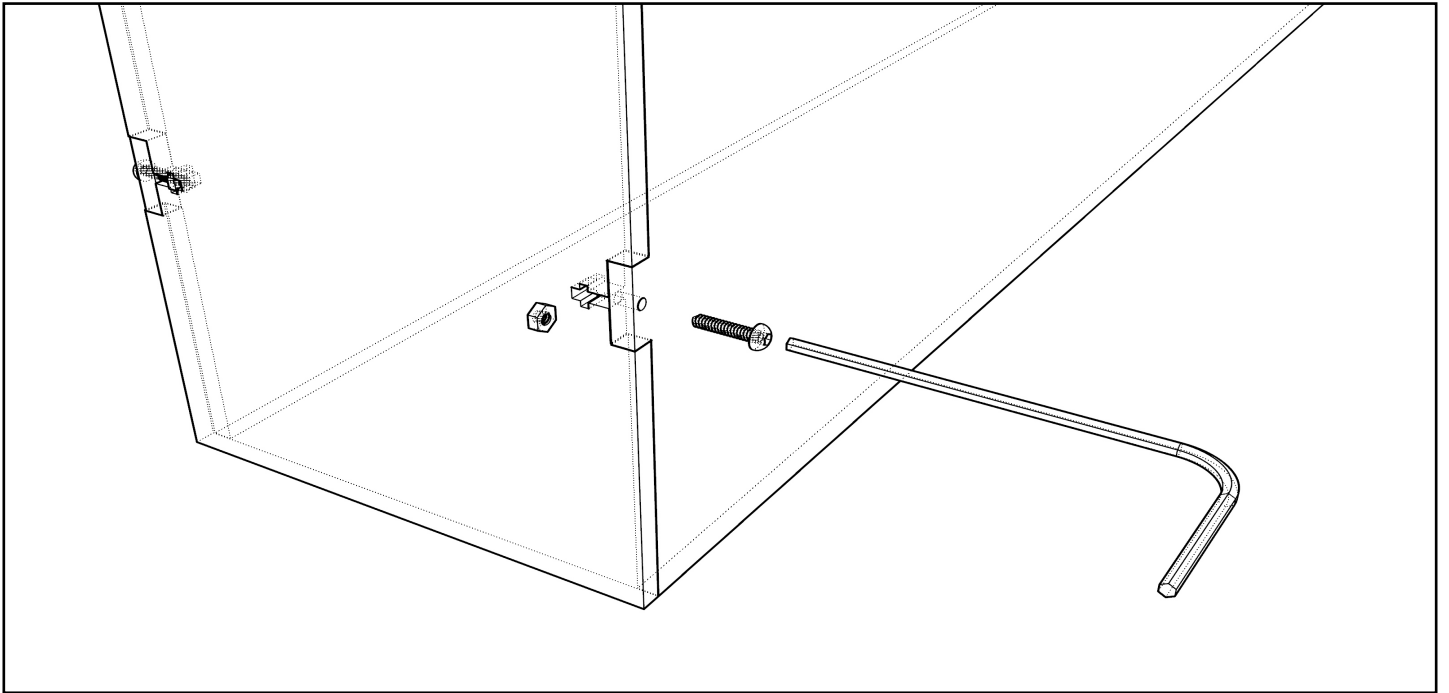

Alternatively, join the sides without screws, slide the screw nut into the slot, and place the screw through the hole into its screw nut.

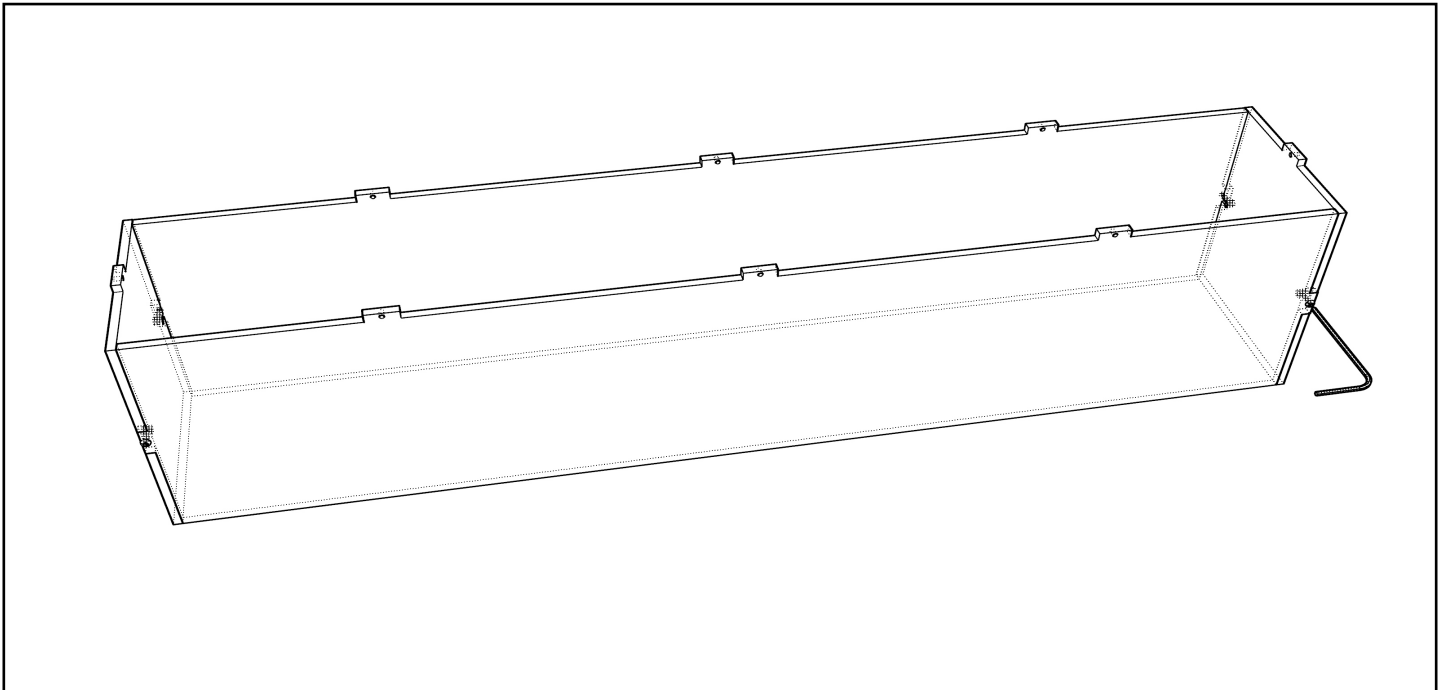

Complete all 4 sides.

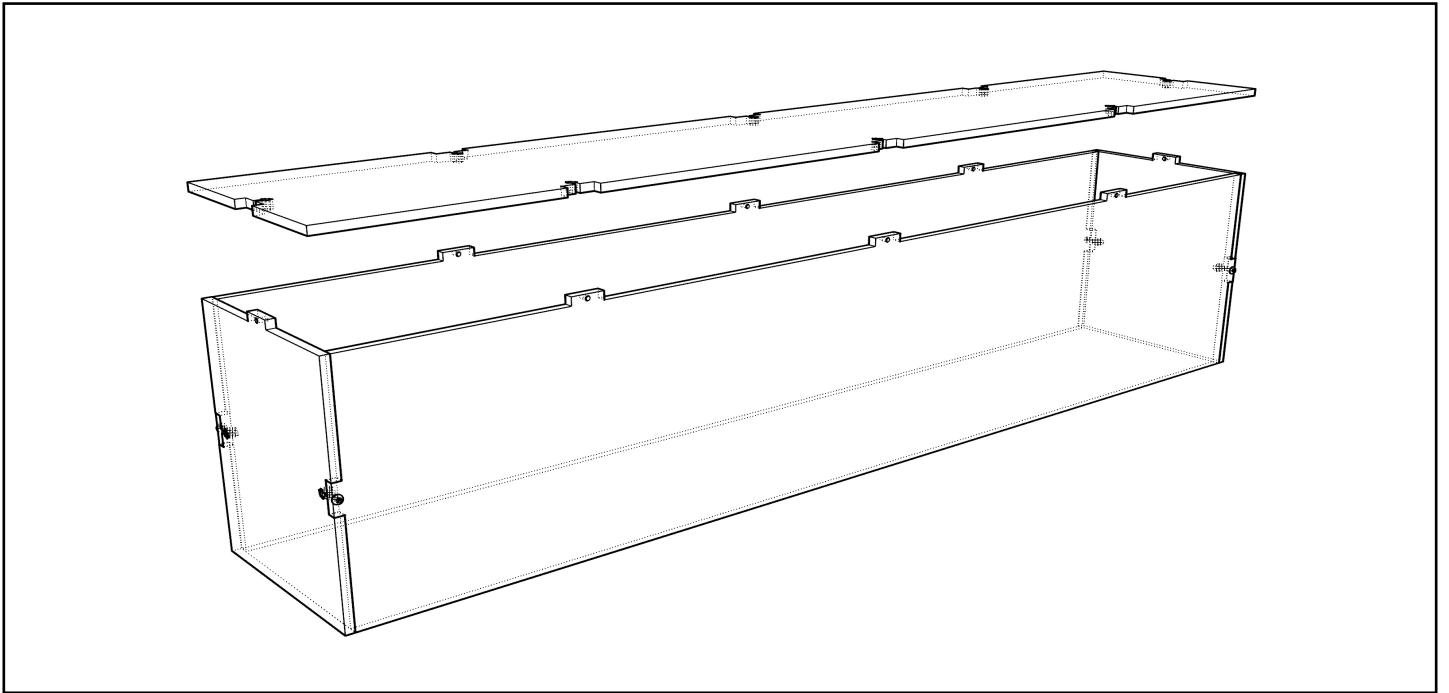

Place the top panel, and turn the box to one of its side.

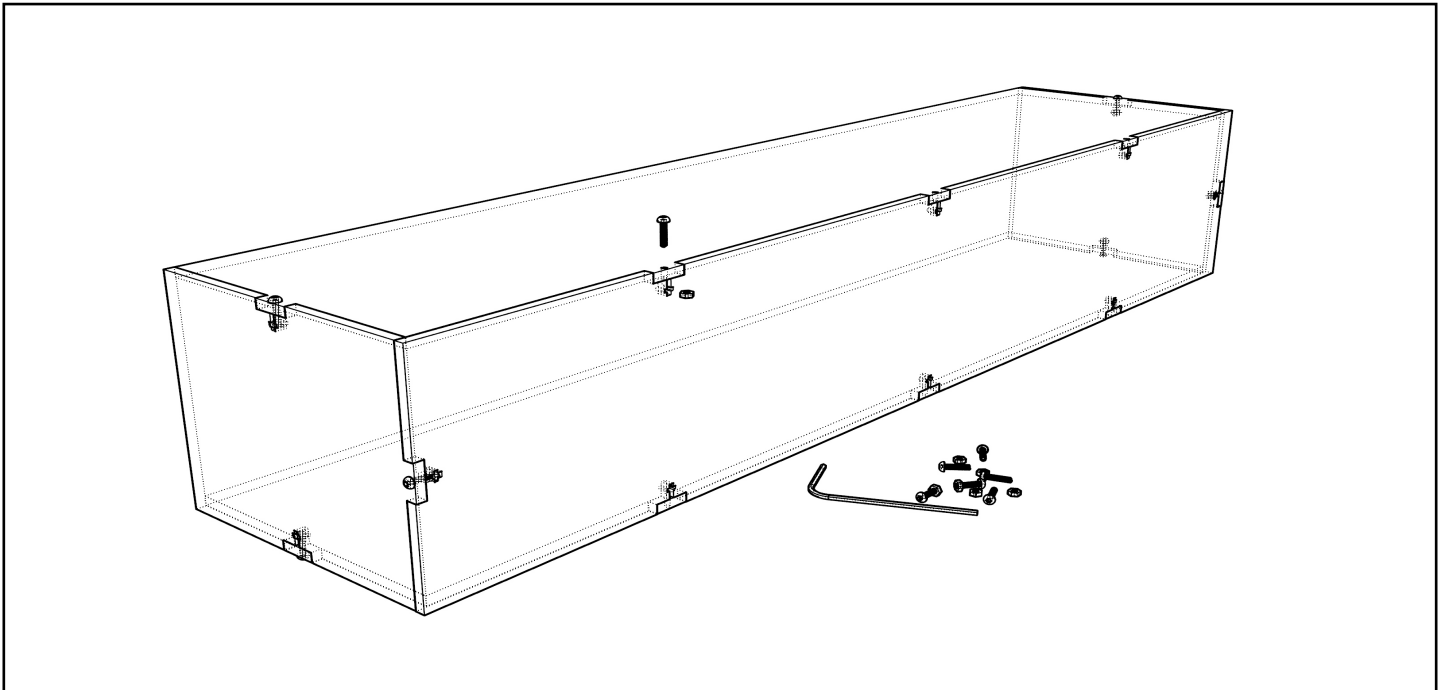

Slide the nut to one of the slots of the T joints, place the screw from the top and tighten it gently.

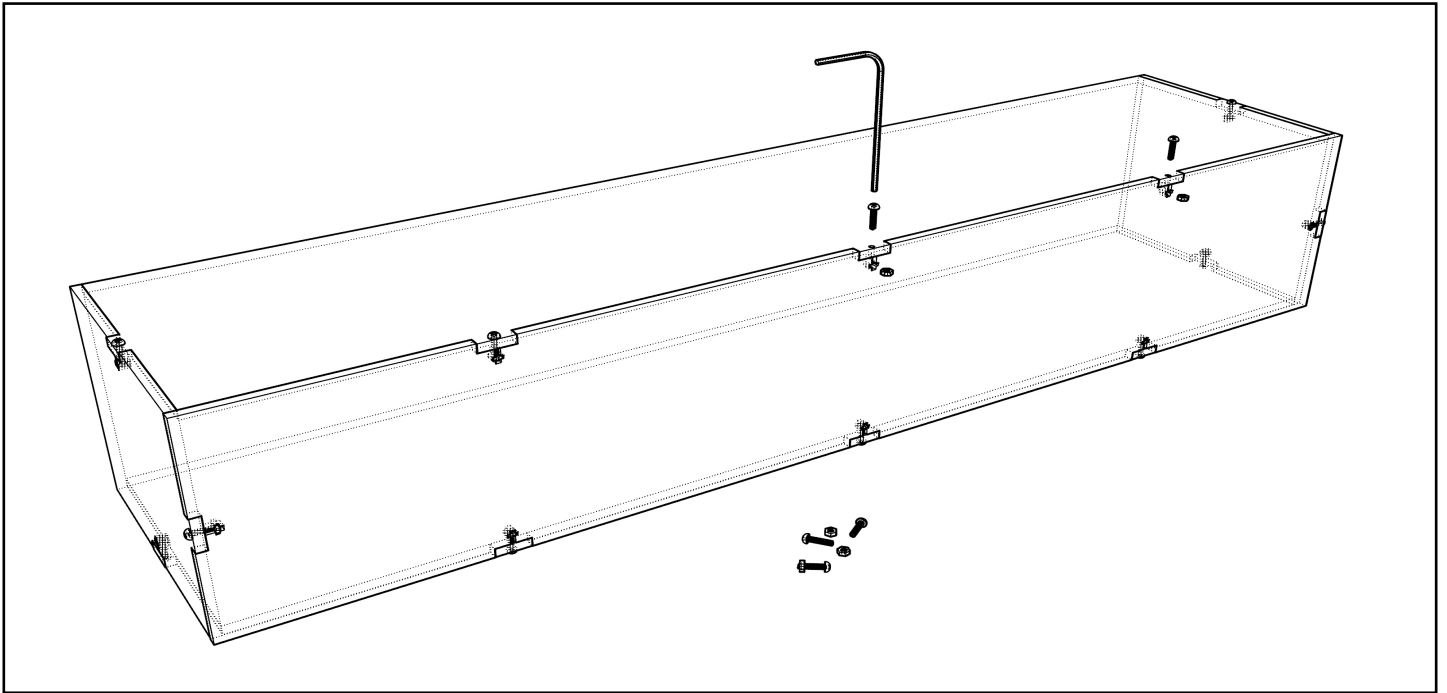

Complete one side of the box and repeat the same on the other 3 sides.

